

Short-Circuit ANSI Comparison Case # 3

Comparison of ETAP 3-Phase Duty Short-Circuit Calculations against Published IEEE Std 399-1997 Example

Excerpts from Validation Cases and Comparison Results (TCS-SC-162)

Highlights

- Comparison of ETAP 3-phase Duty Short-circuit results against a published 44-bus example from the IEEE Std. 399-1997, Section 7.7, pages 187-205.
- Comparison of Momentary fault currents.
- Comparison of Interrupting currents.
- Comparison of ANSI C37.010, C37.05 –1979 Multiplying factors.
- Comparison of calculated individual current contributions and calculated voltages away from the faulted bus.
- Comparison of motor contributions determined according to the Reactance Values specified in Table 7-2 of IEEE Std. 399-1997.
- Comparison of Asymmetrical currents.
- Comparison of Peak currents.
- Comparison of element per-unit impedance representation for motors, generators, cables and lines.

System Description

This is a 44 Bus system as modeled in ETAP. The system has a utility tie and in-plant generators. Both the utility tie and the generators are in service and supplying power to the plant. The system rotating-load is typical of a system operating near to full capacity. The system contains both induction and synchronous motors. The utility is operating at 69 kV and the generators at 13.8 kV. Several motors that are rated less than 50 HP are modeled as composite motors in ETAP. Medium size machines (rated higher than 50 Hp) are modeled individually.

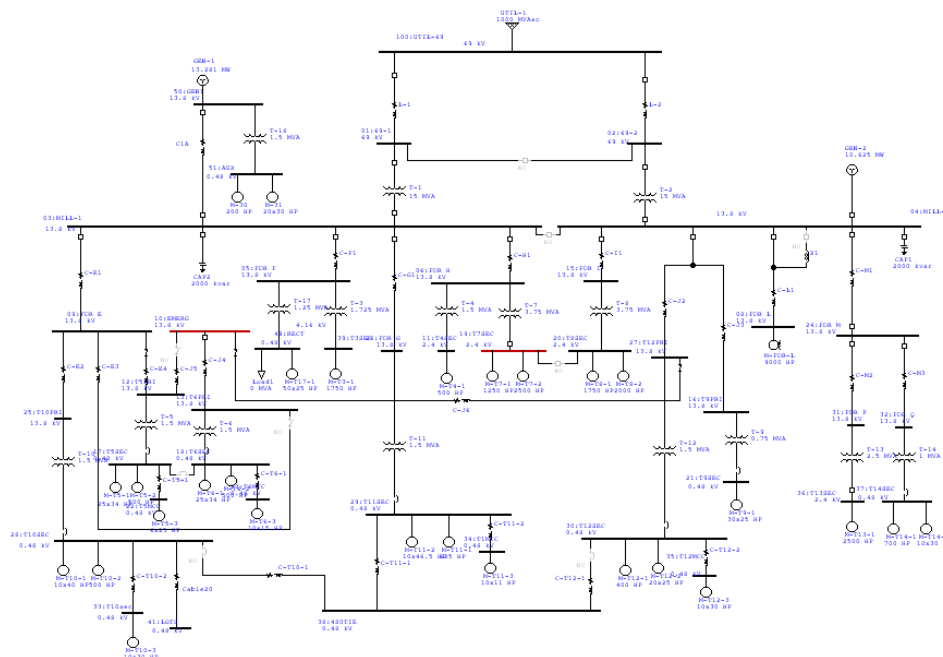

Comparison of Results

The following tables of comparison show the differences between ETAP Results and those published in Tables 7-5 and 7-6 of IEEE Std. 399-1997. The result difference in all cases is less than or equal to 0.1%. Please note that the results have rounded-off and compared to the appropriate number of significant figures.

For a fault at Bus 19: T7SEC	IEEE Std 399-1997 Example	ETAP	% Diff
Prefault Voltage (kV)	2.4	2.4	0.0
Voltage to Ground (at fault location) (%)	0	0	0.0
Total Mom Fault Current (kA)	18.449	18.453	0.0
X/R ratio	13.7	13.7	0.0
Asymmetrical Momentary Current (kA)	27.765	27.762	0.0
Peak Current (kA)	46.879	46.838	-0.1
Contribution from Bus 6:FDR-H2 (kA)	13.418	13.422	0.0
Voltage to Ground (at Bus 6) (%)	82	82	0.0
Contribution from Motor M-T7-1 (kA)	1.619	1.619	0.0
Contribution from Motor M-T7-2 (kA)	3.414	3.414	0.0

Table 7: Comparison of ETAP Momentary Short-circuit results against published IEEE Std 399-1997 Section 7.7 Example results for a fault at Bus 19: T7SEC.

For a fault at Bus 10: EMERG	IEEE Std 399-1997 Example	ETAP	% Diff
Prefault Voltage (kV)	13.8	13.8	0.0
Voltage to Ground (at fault location) (%)	0	0	0.0
Total Mom Fault Current (kA)	11.616	11.616	0.0
X/R ratio	8.95	8.938	-0.1
MF (ANSI Std C37.010 1979)	1	1	0.0
Adjusted Asymmetrical Current (kA)	11.619	11.616	0.0
Peak Current (kA)	46.879	46.838	-0.1
Contribution from Bus 13:T6 PRI (kA)	0.04	0.04	0.0
Voltage to Ground (at Bus 13) (%)	0.0	0.0	0.0
Contribution from Bus 27:T12 PRI (kA)	11.577	11.576	0.0
Voltage to Ground (at Bus 27) (%)	4.0	4.0	0.0

Table 8: Comparison of ETAP Interrupting Short-circuit results against published IEEE Std 399-1997 Section 7.7 Example results for a fault at Bus 10: EMERG.

Reference

1. IEEE Brown Book: IEEE Std. 399-1997, Section 7.7, page 187-205.
2. ETAP Short Circuit ANSI V&V Documents, Case Number TCS-SC-162.