

ETAP Unbalanced Load Flow

The ETAP V&V process for the Unbalanced Load Flow program has over 550 test case scenarios that are run before each ETAP release. The following cases are excerpts from the Unbalanced Load Flow V&V documentation.

Unbalanced Load Flow Comparison Case # 1

Comparison of ETAP Unbalanced Load Flow Results against a Published IEEE 13-Bus Feeder System

Excerpts from Validation Cases and Comparison Results (TCS-ULF-002)

Highlights

- Comparison of ETAP Unbalanced Load Flow (ULF) results against those published in Radial Test Feeders - IEEE Distribution System Analysis Subcommittee for an IEEE 13-bus feeder system found on <http://ewh.ieee.org/soc/pes/dsacom/testfeeders.html>.
- Comparison of bus voltages and angles on each phase.
- Comparison of current flows and angles on each phase.
- The difference in the results is less than 1% for all bus voltages and power flows.

System Description

To model the unbalanced distribution thirteen-bus system found in the web site above, an equivalent system (as shown in Figure 1) was designed in ETAP with the following conditions:

1. This case covers only the portion below Node 632 due to the same ETAP transformer tap for three phases.
2. The portion above Node 632 is modeled using the internal impedances of the utility.
3. Cables are modeled using impedances.
4. The distributed load is modeled using two lumped loads at both line terminals.
5. The single phase load of constant current is modeled using an approximate lumped load.

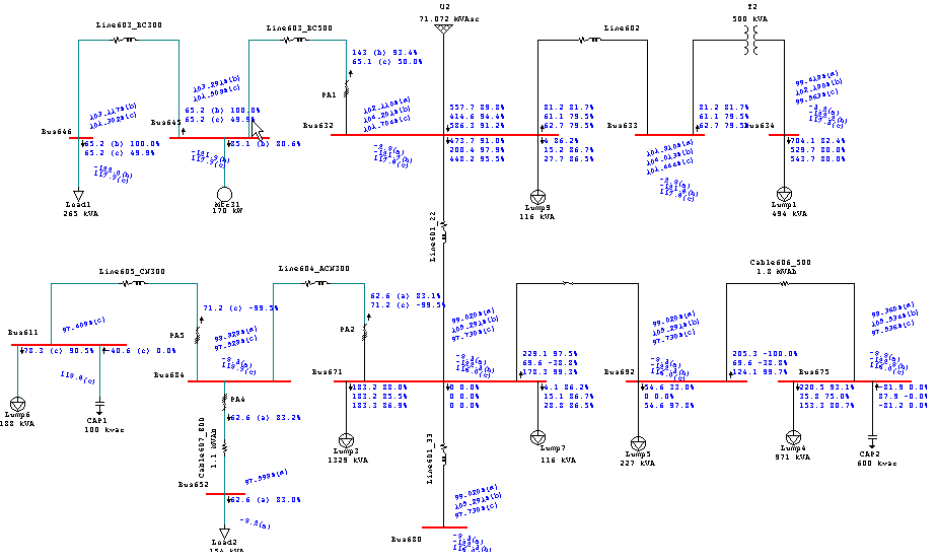

Comparison of Results

The following tables of comparison show the differences between ETAP results and those published on the IEEE 13-bus feeder. Please notice that the percent difference for all branch flows and bus voltages is less than 1%. Any missing fields in the tables below were not provided in the IEEE benchmark results; however, the corresponding ETAP results have been included.

BUS	Voltage (in per unit)								
	Phase A			Phase B			Phase C		
	IEEE	ETAP	% Diff	IEEE	ETAP	% Diff	IEEE	ETAP	% Diff
632	1.021	1.021	0.0	1.042	1.042	0.0	1.017	1.017	0.0
633	1.018	1.018	0.0	1.04	1.04	0.0	1.015	1.014	0.1
634 (XF13)	0.994	0.994	0.0	1.022	1.022	0.0	0.996	0.996	0.0
645				1.033	1.032	0.0	1.015	1.015	0.0
646				1.031	1.031	0.0	1.013	1.013	0.0
671	0.99	0.989	0.0	1.053	1.053	0.0	0.978	0.976	0.0
680	0.99	0.989	0.0	1.053	1.053	0.0	0.978	0.976	0.0
684	0.988	0.987	0.0				0.976	0.974	0.0
611							0.974	0.972	0.0
652	0.982	0.981	0.0						
692	0.99	0.989	0.0	1.053	1.053	0.0	0.978	0.976	0.0
675	0.983	0.982	0.0	1.055	1.055	0.0	0.976	0.974	0.0

Table 17: Bus Voltage Magnitude Comparison

BUS	Angle (in degrees)								
	Phase A			Phase B			Phase C		
	IEEE	ETAP	% Diff	IEEE	ETAP	% Diff	IEEE	ETAP	% Diff
632	-2.49	-2.49	0.0	-121.7	-121.7	0.0	117.83	117.83	0.0
633	-2.56	-2.55	0.4	-121.8	-121.8	0.01	117.82	117.83	0.01
634 (XF13)	-3.23	-3.22	0.0	-122.2	-122.2	0.0	117.35	117.35	0.0
645				-121.9	-121.9	0.0	117.86	117.87	0.0
646				-122	-122	0.0	117.9	117.93	0.0
671	-5.3	-5.29		-122.3	-122.3	0.0	116.02	116.07	0.0
680	-5.3	-5.29		-122.3	-122.3	0.0	116.02	116.07	0.0
684	-5.32	-5.31					115.92	115.96	0.0
611							115.78	115.81	0.0
652	-5.25	-5.24	0.0						
692	-5.31	-5.29	0.0	-122.3	-122.3	0.0	116.02	116.07	0.0
675	-5.56	-5.55	0.0	-122.5	-122.5	0.0	116.03	116.08	0.0

Table 18: Bus Voltage Angle Comparison

To model the distributed load along node “Bus632” to node “Bus671”, the loading is equally connected at each end of the line segment (Line601_22), i.e. Lump9 and Lump7. Therefore, the current flows going from Bus632 to Bus671 and vice-versa are the following:

¹ 632-671:	Phase A:	$474.6 + 4 = 478.6$	² 671 - 632	Phase A:	$474.6 - 4.2 = 470.4$
	Phase B:	$200.6 + 15.1 = 215.7$		Phase B:	$200.6 - 15.1 = 184.9$
	Phase C:	$448.7 + 28.9 = 477.6$		Phase C:	$448.7 - 28.9 = 419.8$

BUS	Current Flow (Amps)								
	Phase A			Phase B			Phase C		
	IEEE	ETAP	% Diff	IEEE	ETAP	% Diff	IEEE	ETAP	% Diff
611							71.2	71.2	0.0
632 - RG60	558.4			414.9			586.6		
-633	81.3	81.2	0.2	61.1	61.1	0	62.7	62.7	0.0
-645				143	143	0	65.2	65.1	0.1
¹ -671	478.2	478.1	0	215.1	215.6	0.2	475.5	475.9	0.1
633 - 632	81.3	81.3	0.1	61.1	61.1	0	62.7	62.7	0.0
-634	81.3	81.3	0.1	61.1	61.1	0	62.7	62.7	0.0
634 - 633	704.8	704.8	0.0	529.7	529.7	0	543.5	543.7	0.0
645-632				143	143	0	65.2	65.1	0.1
-646				65.2	65.1	0.1	65.2	65.1	0.1
646 - 645				65.2	65.1	0.1	65.2	65.1	0.1
652 - 684	63	63	0.0						
² 671 - 632	470.2	470	0.0	186.4	185.3	0.6	420.6	419.8	0.2
-680	0	0		0	0		0	0	
-684	63	63	0.0				71.2	71.2	0.0
-692	229.1	229.1	0.0	69.6	69.6	0.0	178.4	178.5	0.1
675 - 692	205.3	205.4	0.0	69.6	69.6	0.0	124.1	124.3	0.1
680 - 671	0	0		0	0		0	0	
684 - 671	63	63	0.0				71.2	71.2	0.0
-611							71.2	71.2	0.0
-652	63	63	0.0						
692 - 671	229.1	229.1	0.0	69.6	69.6	0.0	178.4	178.3	0.1
-675	205.3	205.4	0.0	69.6	69.6	0.0	124.1	124.1	0.0

Table 19: Current Flow Magnitude Comparison

Reference

1. IEEE Distribution System Analysis Subcommittee for an IEEE 13-bus feeder system found on <http://ewh.ieee.org/soc/pes/dsacom/testfeeders.html>.
2. ETAP Unbalanced Load Flow V&V Documents, Case Number TCS-ULF-002.