

ETAP TIP – No. 007 Composite Network

Applicable ETAP Versions: 5.5.0, 5.5.5, 5.5.6

(For lower versions, some of the descriptions and procedures below may differ in some ways)

In ETAP, we model our electrical network system as a logical diagram called One Line Diagram. We draw the network on a One-line diagram presentation (Refer to ETAP TIP No.001 for more information). Similar to drawing the one line diagram on a paper, the larger the system, the larger the space it occupies on the One-Line diagram presentation. You can layout the entire one line diagram as flat (shows all interconnection details and components in a single page). However, in this manner the presentation tends to look crowded and congested. In addition, when you generate a printout, large size of paper is necessary to get a good clarity of the drawing.

The concept of “Composite Network” was integrated in ETAP to provide flexibility in simplifying and organizing the electrical One Line diagram. The “Composite Network” gives the ability to model a part of the network as a single element on the One Line Diagram. Apparently, this single element gets its common name as a “Composite Network” which represents the part of the network (sub-network). The details of which are drawn on another One Line Diagram Presentation (as if they are drawn on another sheet of paper) as a nest of the former diagram. See Fig. 1.

You can consider a composite network as an aggregation of all components in a sub-network. You can nest your sub-network to an unlimited number of sub-networks (layers).

To demonstrate the “Composite Network”, please run the ETAP program and open the “Example-ANSI.oti” project located at C:\ETAP 55X \Example-ANSI folder (where C: is the drive where you installed Etap program and ETAP 55X is the version of the software).

On the “Study View” One Line Diagram presentation, three (3) composite networks are involved namely “Sub2A-N”, “Sub3 Net” and “DC System”. See Fig. 1

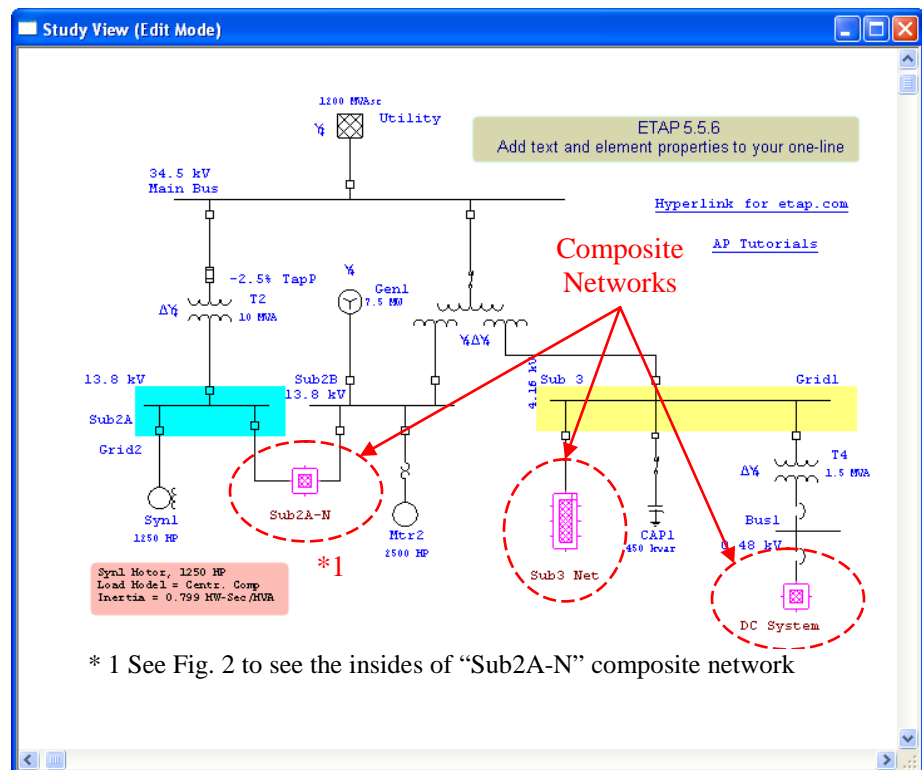

Fig. 1

ETAP TECHNICAL INFORMATION POINTERS

Using your mouse, double-click “Sub2A-N” element. The “Sub2A-N” composite network will be opened and all the components inside it will be displayed (see Fig. 2). Notice in the “Sub2A-N” network, another composite network is involved i.e. “Net1”. In other words, “Net1” is a sub-network of “Sub2A-N”. You may double click on “Net1” to see what are inside it.

You can do the same actions as above to “Sub3 Net” and “DC System” composite network.

Looking at the “Project View” (refer to ETAP TIP No. 001 & 002 for more information), at the “Presentations→One-Line Diagrams-3” folder, you would see sub-folders under the “Study View” folder. These subfolders are the composite networks or composite motors* nested under the “Study View” one line digram. Likewise, in the “Sub3 Net” composite networks are another sub-folders which are the sub networks nested under “Sub3-Net“. See Fig. 3.

*Composite Motor is an element in ETAP similar to Composite network but limited to grouping of loads only. It is only an extension of the bus (where it is connected). It can contain only directly-connected loads (to the bus), their associated protective devices and internal cables (known as equipment cable in ETAP).

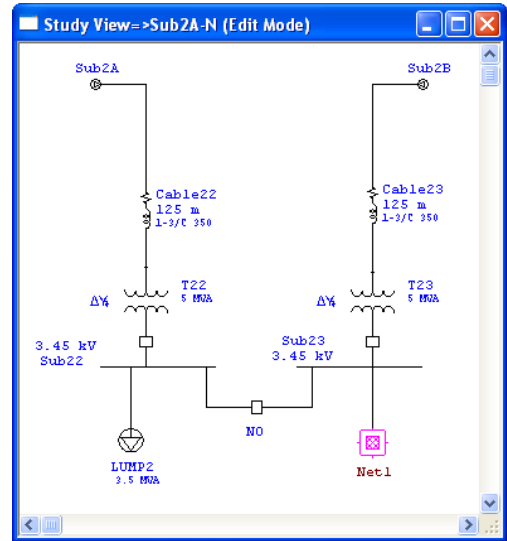

Fig. 2
(Composition of “Sub2A-N” Composite Network)

Working with the Composite Networks:

Composite networks can have up to 20 entry points (pins). The default number of pins is 4. These are top pin, left pin, right pin, and bottom pin. These pins are the gates for connection of the sub-network inside the composite network to the external networks. They can be connected to any bus, branch, load, or protective device. Once a pin is connected internally or externally to an element, it becomes a proxy for that element and all connection rules for the element apply to the connected pin.

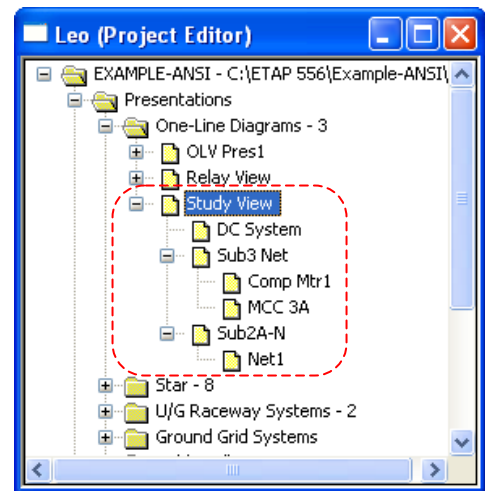
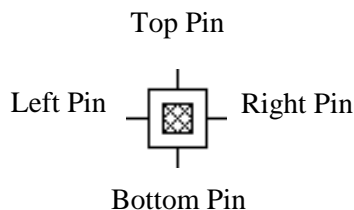



Fig. 3

Illustration:

In the “Example-ANSI.oti” sample project, place “Sub 3” bus including all downstream components connected to it to a composite network and name that network as “Substation 3”. See Fig. 4

Refer to “Toolbars Map” on page 8 of ETAP TIP No. 003 to map out the toolbars that will be identified in the succeeding procedures.

Procedures:

1. Switch to Edit Mode by clicking the “Pencil” icon  on the mode toolbar.
2. Activate the “Study View” one line diagram presentation by clicking its window (or you can go to “project view” and double click “Study View” folder)
3. Click on the “Composite Network” icon on “AC Edit toolbar” and then click anywhere on the canvass to place the element. See Fig. 5
4. Right-Click on composite network element “Net2” and select “Properties” command from the pop-up menu

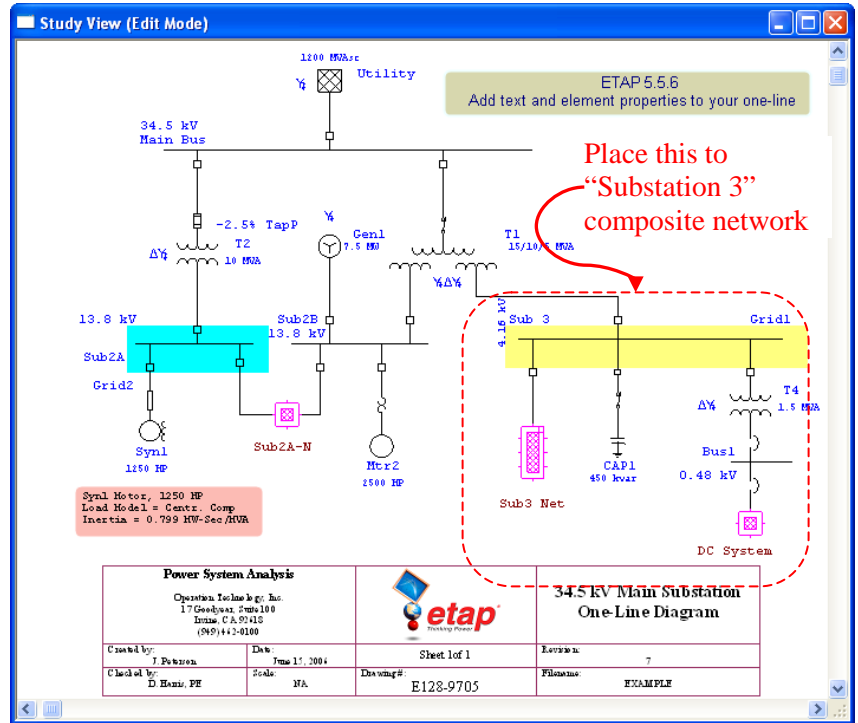
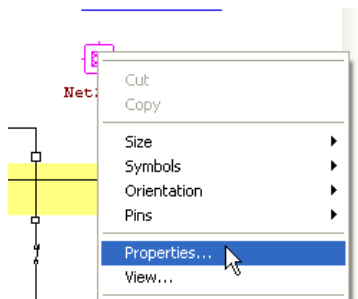

Fig. 4



5. Rename the element to “Substation 3”

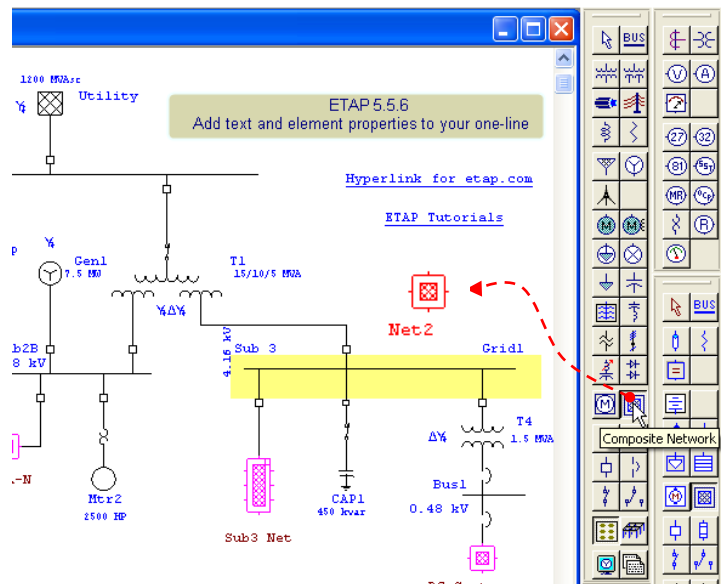
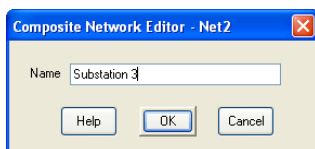

Fig. 5

ETAP TECHNICAL INFORMATION POINTERS

- Rubber band an area enclosing all the components that will be placed to “Substation 3” composite network to select them. See Fig. 6
- Right-click anywhere on the canvass and select “Cut” command from the pop-up menu. See Fig. 7

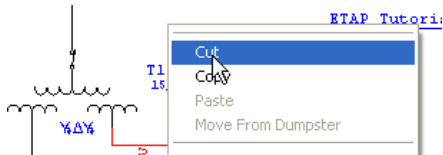

Fig. 7

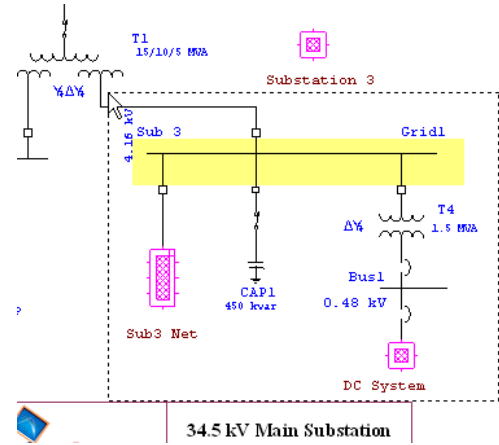

Fig. 6

- Double-click on “Substation 3” composite network. The “Study View=>Substation 3 (Edit Mode)” window (one-line diagram presentation) will open. Note that you will see 4 internal pins inside the window. These pins are the counterpart of the external pins that you see on the composite network symbol. See Fig. 8

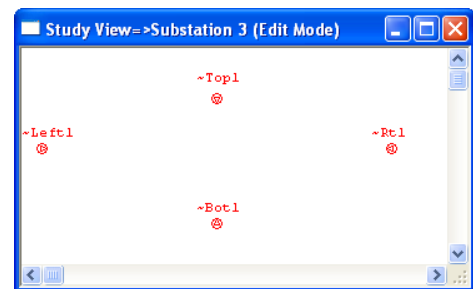

Fig. 8

- Right-click anywhere inside the “Study View=>Substation 3 (Edit Mode)” window and select “Move From Dumpster” command. See Fig. 9

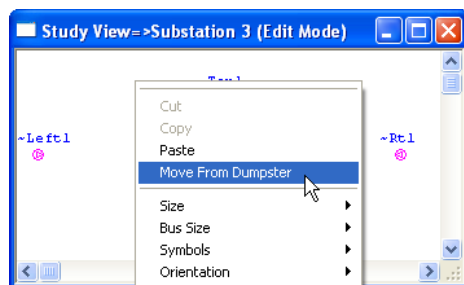

Fig. 9

Note: You can also select the “Paste” command but by doing so, new elements which are replicas of the elements we cut a while ago will be pasted instead of the original elements and new ID would be automatically re-assigned.

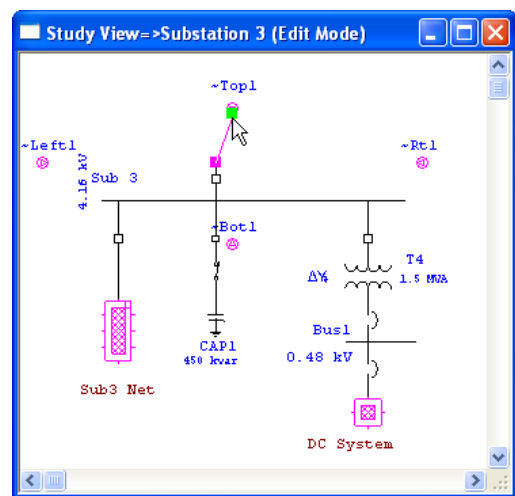

Fig. 10

- Let’s use the “~Top1” internal pin to connect the incomer CB of “Sub 3” bus. Point the mouse on the upper side of the CB and when the “Red” square handle appears, drag the mouse toward the “~Top1” symbol and release the mouse when the “Green” square handle appears on the “~Top1” symbol. See Fig. 10

11. Since we do not need the “~Left1, ~Rt1, and ~Bot1 pins, we may hide them. To do so, right-click anywhere the canvass and select the “Hide Unconnected Pins” command from the pop-up menu. See Fig. 11
12. Now, let’s put back the connection of “Sub 3” bus to the main network. Click anywhere on the “Study View” One line diagram presentation to activate it.
13. Connect the “Top” external pin of the “Substation 3” composite network to the Tertiary terminal of the T1 three-winding transformer. See Fig. 12

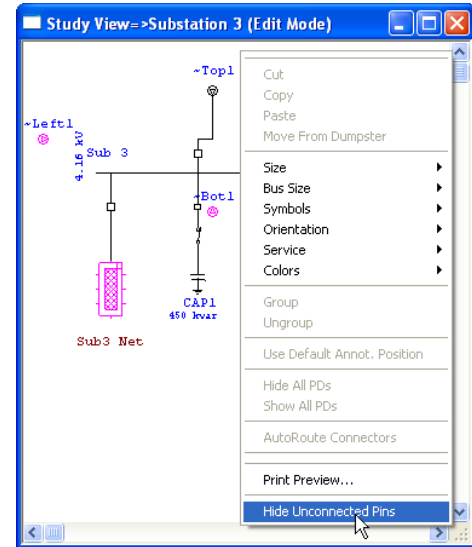

Fig. 11

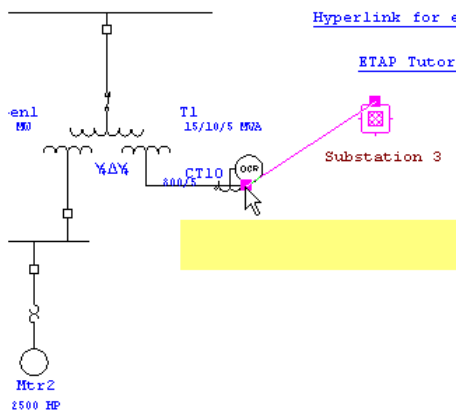

Fig. 12

14. Finally, arrange the position of the elements to the desired presentation. See Fig. 13

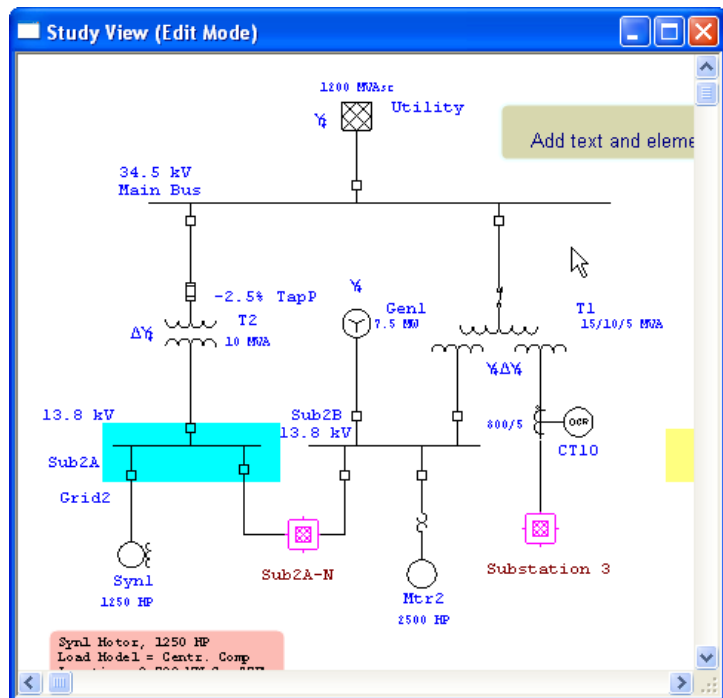

Fig. 13

The one line presentation that we have now in Fig. 13 is completely the same as the one line presentation that we had in Fig. 4 in terms of electrical interconnection and composition.